

CBCS SCHEME

USN

--	--	--	--	--	--	--	--	--	--

17AE/AS34

Third Semester B.E. Degree Examination, Aug./Sept.2020

Mechanics of Materials

Time: 3 hrs.

Max. Marks: 100

Note: Answer any FIVE full questions, choosing ONE full question from each module.

Module-1

- Derive the equilibrium equation for a 3 dimensional stress system. (10 Marks)
 - A state of stress at a point characterized by components $\sigma_x = 100$ MPa, $\sigma_y = -40$ MPa, $\sigma_z = 80$ MPa, $\tau_{xy} = \tau_{yz} = \tau_{zx} = 0$. Determine the extreme value of shear stress associated with normal stress, octahedral shear stress and its associated normal stress. (10 Marks)

OR

- Draw stress strain curve for mild steel and mention the salient point. (05 Marks)
 - Write a note on constitutive laws for anisotropic materials. (05 Marks)
 - A composite bar is shown in Fig.Q2(c). Determine stress developed in each member. $E_{al} = 0.7 \times 10^5$ N/mm², $E_{steel} = 2 \times 10^5$ N/mm².

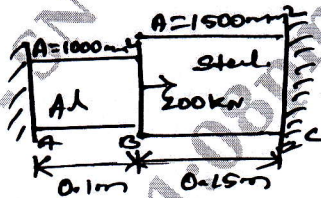

Fig.Q2(c)

(10 Marks)

Module-2

- What are the Euler-Bernoulli assumptions? (05 Marks)
 - A T-section of flange 120mm \times 12mm and overall depth 200mm with 12mm web thickness is loaded, such that at a section, it has moment of 20 kNm and shear force of 120 kN. Sketch the Bending and Shear force distribution diagram. (15 Marks)

OR

- What is three dimensional beam theory give its kinetic description. (10 Marks)
 - What are the equilibrium equations for a beam subjected to transverse loads? (10 Marks)

Module-3

- Obtain the relationship between torque and shear stress in solid circular shaft. (10 Marks)
 - Compare the weight, strength and stiffness of hollow shaft of same external diameter as that of solid shaft. The inner diameter of hollow shaft is half the external diameter. Both the shafts have the same material and length. (10 Marks)

OR

- Explain the procedure to determine the shear flow distribution over the open c/s of thin walled beam subjected to transverse shear forces. (10 Marks)

- b. Calculate the position of shear centre of thin walled channel section shown in Fig.Q6(b), thickness being constant.

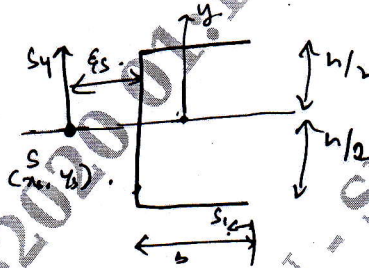

Fig.Q6(b)

(10 Marks)

Module-4

- 7 a. What are the differences between principle of virtual work and principle of complementary virtual work? (10 Marks)
 b. Explain the steps involved in unit load method applied to truss structures. (10 Marks)

OR

- 8 a. Explain Maxwell's theorem. (10 Marks)
 b. A simply supported beam of span 'L' carries a point load F at mid span. Determine strain energy stored by the beam. Also find deflection at mid span. (10 Marks)

Module-5

- 9 a. Explain theory of failure (Stain energy). (10 Marks)
 b. A beam ABC 5m long is hinged at 'A' and supported by vertical props BD and CE at B and C as shown in Fig.Q9(b). Beam carries a load of 20 kN at the middle of BC. $E_{BD} = 1 \times 10^5 \text{ N/mm}^2$; $E_{CE} = 2 \times 10^5 \text{ N/mm}^2$. Find the load transmitted by the props.

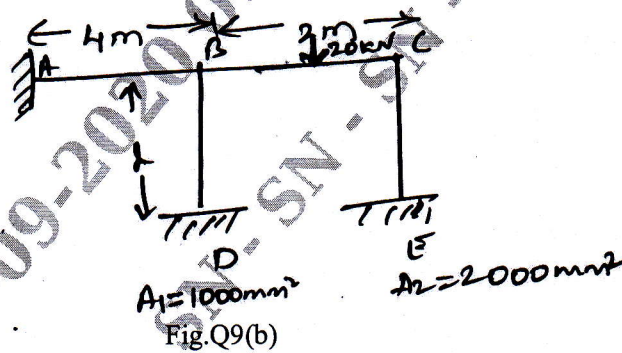

Fig.Q9(b)

(10 Marks)

OR

- 10 a. Explain Kirchoff plate theory and mention its assumption. (10 Marks)
 b. What are the constitutive laws for laminated composite plates? (10 Marks)
